

ABSORB-M™ | NON-REDIRECTIVE CRASH CUSHION

- ANCHORLESS INSTALLATION - NO FOUNDATION REQUIRED
- EASY TO DEPLOY AND REMOVE
- MASH TL-3 COMPLIANT

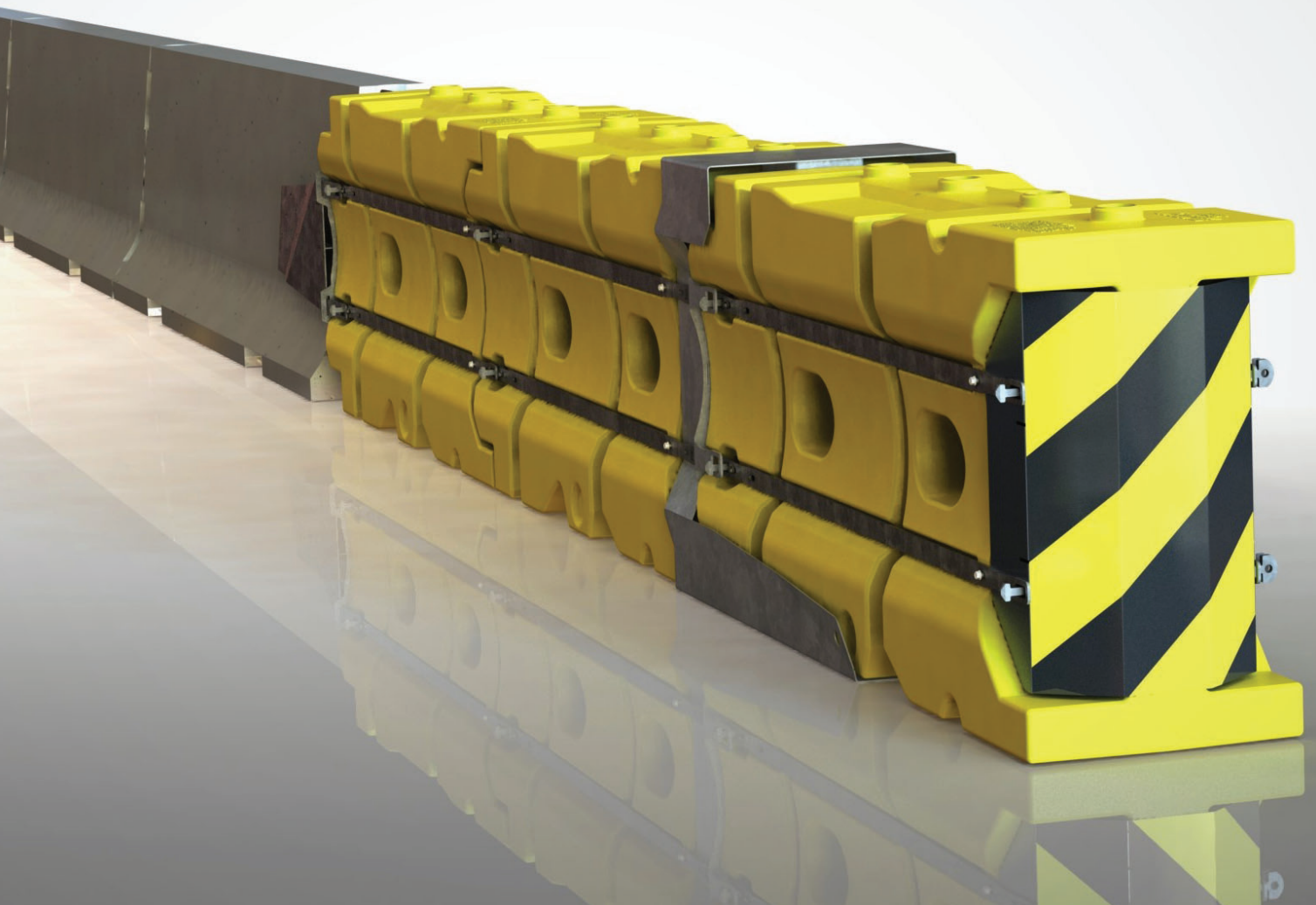

PHYSICAL SPECIFICATIONS

Classification	Non-Redirective MASH TL-3	
TL-3 Length	21'	639 cm
Width	26"	67 cm
Height	43 1/4"	110 cm
Element Weight Empty	180 lb.	81 kg
Element Weight Full	2270 lb.	1030 kg

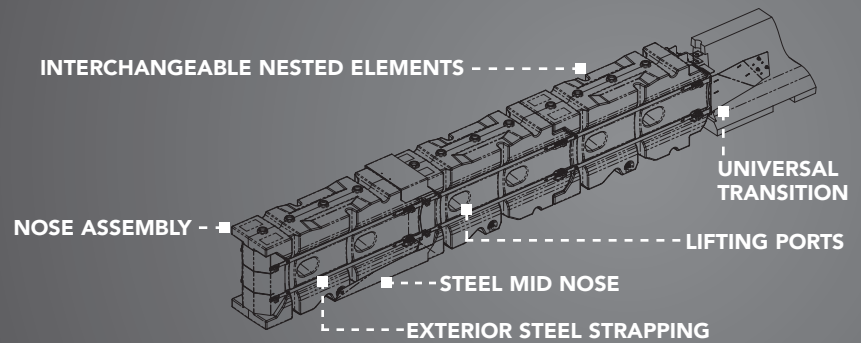

NARROW ANCHORLESS WATER FILLED CRASH CUSHION

No ground anchoring, easy deployment/removal, and the shortest length in its class, make the ABSORB-M system the contractor's choice for a work zone ready MASH crash cushion. At 26" (67 cm) wide, it is suited for narrow areas where road and workspace is limited. The system utilizes interchangeable, nested elements to reduce inventory costs and a universal transition takes time and complexity out of installation.

FREQUENTLY ASKED QUESTIONS

What types of barrier can the ABSORB-M system be used on?

The ABSORB-M system is designed to accommodate a variety of safety shape and constant slope barriers between 32 in. to 42 in. tall.

Can the ABSORB-M System be moved while filled with water?

Yes, the System is rigid enough to be repositioned filled with water by lifting each element from the integrated fork lift port

Can the ABSORB-M System be used during cold weather?

Yes, since ABSORB-M elements have no internal steel parts, the use of any approved anti-icing chemical is acceptable.

FEATURES

- » Rapid deployment and retrieval
- » No ground anchoring required
- » Universal transition
- » Narrow footprint
- » Can be deployed on almost any road surface
- » Shortest MASH TL-3 non-redirective, anchorless crash cushion
- » Acceptable for use on anchored and unanchored barrier
- » Approved for use in permanent and work zone locations

DISTRIBUTED BY:



Lindsay Transportation Solutions Sales and Services, Inc.

18135 Burke Street, Suite 100 • Omaha, NE 68022 • +1 (402) 829-6800 U.S. Toll Free: (888) 800-3691 • www.lindsay.com

General details for the ABSORB-M System are subject to change without notice to reflect improvements and upgrades.

Additional information is available from Lindsay Transportation Solutions Sales and Services, Inc. © Lindsay Transportation Solutions, Inc.

PT # ABS04-04172019